



# Clark County Department of Building & Fire Prevention

4701 West Russell Road, Las Vegas, NV 89118 ~ (702) 455-3000

## Grading in Conjunction with a Residential Subdivision or Parcel Map Building Permit Guide

Jerome A. Stueve, P.E., Director  
Samuel D. Palmer P.E., Assistant Director • Girard Page, Fire Marshal

### Part I. General Information

In order to acquire a grading permit in conjunction with a residential subdivision (Final Map) or Parcel Map application, the following review and approval process must be completed. (To ensure that your application is processed in a timely manner, all submittals must be complete. Refer to Exhibits "A" and "B" for further details.)

### Part II. Technical Study Submittal & Review Process

The submittal and review process for a technical drainage study can be found on the Public Works Development Review webpage. See the hyperlink below.

<http://www.clarkcountynv.gov/public-works/development/Forms/Submittal%20Guidelines%20and%20fees.pdf>

<http://www.clarkcountynv.gov/public-works/development/Forms/Submittal%20Sheet%20Drainage%20Study.pdf>

**Note:** Parcel Map submittal requirements are on the Public Works webpage. See the hyperlink below..

<http://www.clarkcountynv.gov/public-works/surveyor/Pages/forms.aspx>

### Part III. Off-site Plan Submittal & Review Process

The Public Works Development Review onsite grading permit approval options are shown on their webpage. See the hyperlink below.

<http://www.clarkcountynv.gov/public-works/development/Forms/On%20Site%20Grading%20Submittal%20Options.pdf>

**NOTE:** An Off-Site Improvement Permit to perform designated work within the public right-of-way may be obtained from Public Works Development Review only after the Final Map/Parcel Map has been approved for recordation.

### Part IV. On-Site Grading Permit Submittal & Review Process

1. Applicant submits the following documents to Building Plan Submittal for review and approval of an on-site grading permit:
  - Completed Building Permit Application.
  - One (1) copy of the drainage study approval letter.
  - Three (3) copies of the grading plan along with any associated detail sheets. (Note: If other than Public Works Development Review copies, must have original stamp and signatures).
  - Two (2) original copies of the geotechnical (soils) report dated within the last twelve (12) months. One (1) photocopy of the geotechnical report for review with the ESGI CD.
  - One (1) CD of the Electronic Submittal of Geotechnical Data (ESGI)
  - Stormwater Pollution Prevention (SWPPs) documentation

---

**NOTE:** On Parcel Maps that only require a grading plan, submit a copy of the Parcel Map Determination Sheet in lieu of the drainage study approval letter.

2. Building Plan Submittal will assign an application number to the submittal package for tracking and information purposes and coordinate the permit application review.

**NOTE:** In order to expedite the review time, ensure that the Final Map technical review has been submitted to Current Planning, all land use applications have been approved by Current Planning, the grading plan mylars have been approved by Public Works Development Review, and copies of the Public Works Development Review approved mylars are included in your plan submittal package.

3. Two (2) plan sets are routed to Current Planning Zoning Plans Check and one (1) plan set is routed to Building Plans Examination for concurrent reviews.
4. The Building Department Engineering Division review process is as follows:
  - Review of the geotechnical (soils) report and grading plan.
  - Coordination of any corrections/revisions to the geotechnical (soils) report and grading plan with the applicant.
5. CURRENT PLANNING ZONING PLANS CHECK will review to verify compliance with the following and will coordinate any corrections/revisions with the applicant and Public Works Development Review:
  - Title 28, 29 and 30.
  - Tentative Map.
  - Final Map (submitted for technical review).
  - Any Commission imposed conditions of approval.
6. Upon verification of the above, if copies of the approved grading plan mylars were submitted, Current Planning Zoning Plans Check will approve the on-site plans and route to Building Department Engineering Division. If plans are not copies, the application will be placed on hold. Once Public Works Development Review has approved mylars, the applicant must submit two (2) certified copies to Current Planning Zoning Plans Check so that the hold can be removed from the application.
7. Building Department Engineering Division performs a final review of the following prior to approval of the on-site plans. Upon approval, the application is sent back to Building Plans Submittal.
  - On-site plans.
  - Document preparation.
8. BUILDING PLANS SUBMITTAL will notify the applicant when the application has been approved and fees have been calculated. The applicant will be required to submit the following documents in addition to paying the permit and Desert Conservation Mitigation and Administrative fees to Permit Application to receive the permit:
  - Clark County Air Quality Management Dust Control Permit.
  - Signed Quality Assurance Agreement (QAA).

**NOTE:** Federal Law requires the issuance of a Storm Water Discharge Permit when construction activities disturb one (1) or more acres of land and discharge storm water. For additional

---

information on requirements and/or questions, applicants should contact the Nevada Bureau of Water Pollution Control at (775) 687-4670, ext. 3149.

## **Part V. Inspection Requirements**

The applicant is responsible for scheduling all appropriate inspections and/or submitting any required reports. Information related to on-site inspection requirements may be obtained from the Department of Building Inspections Division. Information related to off-site inspection requirements may be obtained from Public Works Development Review.

**NOTE:** For your convenience and to help expedite your inspection requests, the Clark County Department of Building offers both an automated telephone inspection scheduling system and inspection scheduling via the Internet.

To use the automated Telephone System, call (702) 455-3000, press “1” to select inspections, and follow the prompts. You will need the phone system number and 4-digit inspection type codes which are located on both the permit and inspection record forms.

To schedule an inspection online, visit [www.ClarkCountyNV.gov/building](http://www.ClarkCountyNV.gov/building) and click on the “Permit Inspections Electronic Reviews” button. Then click on the link to “Schedule or Cancel Inspections.” Access requires permit and Internet P.I.N. numbers which are printed at the top of the permit form.

Any permits that require a Civil Engineering clearance will need to schedule an inspection with the Public Works Development Review Inspections Division by calling 702-455-4610.

---

## EXHIBIT A DRAINAGE PLAN REQUIREMENTS

The following items must be included on all drainage plan submittals:

1. Sheet size: 24" x 36"
2. Minimum scale: 1" = 50'
3. Project name
4. Vicinity map
5. Revision box
6. North arrow and bar scale
7. Professional engineer's signature, seal, and date
8. Engineer's consultant's address and phone number
9. Elevation datum and benchmark (NAVD 88)
10. Legend for symbols and abbreviations
11. Cut/fill scarps (where applicable)
12. Street names, grades, and widths
13. Spot grades for top of curbs and street crowns at lot lines, grade breaks, and along curb returns
14. Existing contours encompassing the site and 100 feet beyond with spot elevations for important in excess of 100 feet where appropriate.
15. Minimum finish floor elevations for all building and levels.
16. Typical street sections
17. Proposed contours or spot elevations in sufficient detail to exhibit intended drainage patterns and slopes
18. Property lines
19. Right-of-way lines and widths (existing and proposed)
20. Existing improvements and their elevations
21. Delineation of proposed on-site drainage basins indicating area and 10-year and 100-year storm peak flows at basin concentration points
22. Drainage flow direction with Q100 and V100
23. Cumulative flows, velocity and direction of flow at upstream and downstream ends of site for the 10-year and 100-year flows
24. Cross-sectional detail for channels, including cutoff wall locations
25. Existing and proposed drainage facilities, appurtenances and connections (i.e., sidewalk, ditches, swales, storm drain system, unimproved and improved channels and culverts, etc), stating size, material, shape, and slope
26. Existing and proposed drainage easements and widths shown with sufficient detail
27. Location and detail of existing, proposed, and future block wall openings
28. Detail of flood walls illustrating depth of flow, proposed grouting height, etc.
29. Retaining wall locations with top of wall and top of foundation elevations.
30. Building and/or lot numbers
31. Alignment of all existing, proposed, or future regional facilities adjacent to site
32. Limits of existing floodplain based on current FIRM.

For areas in Zone A, AE, AH, and AO, base flood elevations (BFE's) must be shown for each lot, in addition to the aforementioned items. BFE's may be listed on each lot, or in a table.

---

## EXHIBIT B GRADING PLAN REQUIREMENTS

### A. Grading Plans:

The following items must be included on all grading plan submittals:

**The requirements on this checklist are not intended to be all inclusive, nor do they entail a limit to the extent of the information, etc., which may be necessary to properly evaluate the submitted plans.**

General information  
Excavations, Fills & Hillside Grading  
Foundations & Wood Construction  
Basement  
Geotechnical Requirements – Soils Report  
Zoning Requirements  
Storm water Compliance Requirements

### Code References Used:

**ACI-318:** Section 4.3 – sulfate exposures and requirements

**ASCE 7-10:** Section 11.8 geologic hazard and geotechnical investigation report; requirements for liquefaction evaluation

**BMP:** [Las Vegas Valley Construction Site BMP Guidance Manual Section 3.5.1](#) – Standard notes 1-5 for Stormwater Runoff Management Program

**HCDDM** – Hydrologic Criteria and Drainage Design Manual

**IBC** – International Building Code

**NAC** – Nevada Administrative Code

**NRS** – Nevada Revised Statutes

**PTI** – Section 1808.6.2 of the IBC refers PTI for P/T Slab-on-grade requirements

**PDPP** – Policy and Procedures

**SF2** – Standard Form2

**SNBCA** – Southern NV Building Code Amendments  
SNBCA Appendix J, Section 104  
SNBCA Sections 1802, 1803, 1805

**Supplement** Clark County Supplement to Uniform STD Drawings & Spec. Chapter 2, 1 B

**Title 30** – Clark County Unified Development Code

30.8 – Definition  
30.16 – Land Use Application  
30.24 – Planned Unit Development  
30.36 – Zoning Districts and Maps  
30.48 – Zoning Overlay Districts  
30.56 – Site Development Standards  
30.60 – Parking & Loading Regulations  
30.64 – Site Landscape & Screening Standards

## Grading Plan Review Checklist

√	#	Grading Plan Requirements - General	Building Review Code Reference	Civil Review Code Reference
	1	Minimum Required Sheet Size: 24" x 36"		HCDDM SF2
	2	All sheets must be legible – must be reproducible in our electronic files		HCDDM SF2
	3	Legend identifying CC approved Standard Symbols and Abbreviations		HCDDM SF2
	4	North Arrow and Bar scale (on each sheet) 1" = 60' Smallest		HCDDM SF2
	5	Registered design professional/Engineer original seal (wet seal), signature and date or a Records stamp and signature stating, "This is a true and exact copy of the original document on file in this office."	SNBCA J104.2	NAC 625.610
	6	Date and expiration date of Engineer's stamp		NAC 625.610
	7	Engineer's name, address, phone number & fax		NAC 625.611
	8	Revision Box		HCDDM SF2
	9	Project Name – address and location of property	NAC 625.611	NAC 625.611
	10	General vicinity of the proposed site and vicinity map.	SNBCA J104.2	HCDDM SF2
	11	Property line limits and accurate contours of existing ground and details of terrain and area drainage.	SNBCA J104.2	HCDDM SF2
	12	Limiting dimensions, elevations or finish contours to be achieved by the grading, proposed drainage channels and related construction. <ul style="list-style-type: none"> <li>▪ Proposed contours</li> <li>▪ Pad elevations or finished grades at all building corners</li> </ul>	SNBCA J104.2	HCDDM SF2
	13	Location of any buildings or structures on the property where the work is to be performed and the location of any buildings or structures on land of adjacent owners that are within 100 feet of the property or that may be affected by the proposed grading operation. Existing adjacent finish floor elevations that are within 100 feet of the property or may be affected by the proposed grading operation	SNBCA J104.2	HCDDM SF2
	14	Recommendations included in geotechnical and the engineering geology report shall be incorporated in the grading plans or specifications as follows: <ul style="list-style-type: none"> <li>(a) Locations and dimension of all cut and fill slopes</li> <li>(b) Locations of all cross sections presented in the geotechnical report</li> <li>(c) Locations and sizes of all recommended remedial measures such as buttress fills, stability fills, deep foundation systems, reinforced earth, retaining walls, etc.</li> <li>(d) Location and layout of proposed sub-drainage system.</li> </ul>	SNBCA J104	
	15	A statement that the site shall be graded in accordance with the approved geotechnical report. This statement shall include the firm name that prepared the geotechnical report, the report number, and the date of the geotechnical report.	SNBCA J104.2	
	16	Locations of other existing topographic features whether natural or manmade such as streets, drainage structures, mapped faults, pavements, walls, etc. Existing condition of the streets: Paved/Gravel/Unimproved Proposed driveway location(s) and elevations	SNBCA J104.2	HCDDM SF2 HCDDM SF2

## Grading Plan Review Checklist

√	#	Grading Plan Requirements - General	Building Review Code Reference	Civil Review Code Reference
	17	The cut to fill transition line (where no over-excavation is required).	SNBCA J104.2	
	18	Details and cross sections at property lines, fence walls, retaining walls, berms, etc. <ul style="list-style-type: none"> <li>▪ Proposed retaining walls and top of wall elevations</li> <li>▪ Details of retaining walls, showing maximum total height of retaining wall &amp; screen wall</li> <li>▪ Details of fences/block walls &amp; beams (existing and proposed)</li> <li>▪ Details of flood walls and footings</li> <li>▪ Details of drainage swales</li> <li>▪ Details of block wall openings for drainage (existing and proposed)</li> <li>▪ Detail of sidewalk under drains</li> </ul>	SNBCA J104.2	HCDDM SF2
	19	Details and cross sections of typical fill slopes and cut slopes.	SNBCA J104.2	HCDDM SF2
	20	Typical details of fill-over-natural slopes and fill-over-cut slopes where fill is to be placed on natural or cut slopes steeper than 5H:1V in accordance with Section J107.	SNBCA J104.2	
	21	Elevation datum and benchmark as established by the NAVD88, Clark County benchmark	SNBCA J104.2	HCDDM SF2
	22	Existing contours must extend at least 100 feet beyond the property lines.	SNBCA J104.2	HCDDM SF2
	23	Proposed finish contours or spot elevations at the property corners, building pad, and at swale flow lines. <ul style="list-style-type: none"> <li>▪ Elevations at all lot corners and along lot lines.</li> <li>▪ Spot elevations, drainage arrows, flow line elevations, and grade breaks</li> </ul>	SNBCA J104.2	HCDDM SF2
	24	Elevation of curbs, crown elevation, or centerline of roads or streets. <ul style="list-style-type: none"> <li>▪ Top of curb or edge of pavement and crown elevations at lot lines and/or extension of lot lines</li> <li>▪ Street names (Public or Private)</li> </ul>	SNBCA J104.2	HCDDM SF2
	25	Earthwork quantities in cubic yards.	SNBCA J104.2	
	26	Finish floor elevation(s). <ul style="list-style-type: none"> <li>▪ Finish floor elevations for any sunken floors</li> <li>▪ Minimum finish floor Elevation = FULL NUMBER PLUS TWO DECIMALS (0000.00)</li> <li>▪ Minimum finish floor elevation – 18" above centerline or top of curb • whichever is greater (Clark County Supplement to Uniform STD Drawings)</li> </ul>	SNBCA J104.2	HCDDM SF2
	27	Setback dimensions of cut and fill slopes from site boundaries per Section J108.	SNBCA J104.2	HCDDM SF2
	28	Drainage Across Property Lines – concentrated drainage not allowed unless easement.	SNBCA J109.4	HCDDM SF2
	29	Location of fault lines and setbacks.	SNBCA 1805.1.1	HCDDM SF2
	30	Base flood Elevation in Zone A, AE, AH, AO, reference FIRM or approved Drainage Study		HCDDM SF2
	31	Limits of flood zones, reference FIRM Panel, Series & Date		HCDDM SF2



## Grading Plan Review Checklist

√	#	Grading Plan Requirements - Excavations, Fills & Hillside Grading: (SNBCA Appendix J)	Building Review Code Reference
	1	Maximum Slope. The slope of cut surface shall be no steeper than 2H:1V, otherwise, provide a slope stability analysis.	SNBCA Appendix J 106.1
	2	Building Placement. The placement of buildings and structures on and or adjacent to slopes steeper than 3H:1V (33.3% slope) shall be in accordance with Section 1808.7.	SNBCA Appendix J104.2
	3	Benching/Key. Check for areas of existing terrain with a slope greater than 5:1. Ensure the grading plan incorporates the recommendations of the soils report and Appendix J for the placement of fill on slopes steeper than 5:1. Provide details and cross sections of typical fill slopes and cut slopes. Locate key on grading plan.	SNBCA Appendix J107.3
	4	Setbacks. Cut & fill slopes shall be set back from foundations per Figure J108.1.	SNBCA Appendix J108
	5	Provide the locations and dimensions of all terrace drains for all slopes steeper than 3H:1V, as required.	SNBCA Appendix J108
	6	<u>Terracing</u> Check slopes steeper than 3H:1V (30' high) for terracing requirements.	SNBCA Appendix J109.2
	7	<u>Interceptor Drains</u> Provide the locations and dimensions of all terrace drains for all slopes steeper than 3H:1V.	SNBCA Appendix J109.3
	8	<u>Erosion Control</u> Applies when slopes greater than 3H:1V, 20' in height.	SNBCA Appendix J110

√	#	Grading Plan Requirements – Foundations & Wood Construction:	Building Review Code Reference
	1	The plan shall show positive drainage of a minimum 5% away from foundations for 10' or to swale; exception – sand and gravel site or low expansive clay/silt (2%). Swales shall slope a minimum of 1%.	SNBCA 1804.3
	2	Where wood wall construction is used, finish grades shall allow for a minimum 8" of clearance from the finish floor elevation to the adjacent exterior grade (soil/landscape).	IBC Chapter 2304.11.2.2

√	#	Grading Plan Requirements – Basements:	Building Review Code Reference
	1	Structures with basements must show: <ul style="list-style-type: none"> <li>▪ All openings to basement</li> <li>▪ Top of Window well/bottom of window (if no well) elevations</li> <li>▪ Positive drainage away from all basements openings</li> <li>▪ Basement finish floor/an improved administrative waiver of finished floor</li> <li>▪ Main Floor Finish Floor</li> </ul>	SNBCA J104.2
	2	Foundation walls shall be designed to support the weight of the full hydrostatic pressure backfill without drainage unless a drainage system is installed.	IBC 1805



## Grading Plan Review Checklist

√	#	Geotechnical Requirements - Soils Report:	Building Review Code Reference
	1	Engineer original seal, signature, and date on at least one copy of the soils report.	NRS
	2	All geotechnical reports must be current within the last 12 months. Any report older than 12 months must be accompanied by a wet sealed update letter addressing the current site conditions based on a recent site visit.	SNBCA 1803.6
	3	A plot showing the location of test borings and/or excavations. The plot shall be dimensioned and show the location of all existing structures.	SNBCA 1803.6
	4	Minimum number/depth of required explorations.	SNBCA 1803.3.2
	5	A complete record of the soil samples, a record of the soil profile and depth of the water table, if encountered.	SNBCA 1803.6
	6	Recommendations for foundation type and design criteria, including but not limited to: bearing capacity and mitigation of the effects of expansive soils, liquefaction, differential settlement, varying soil strength, adjacent loads, collapsible soils, soluble soils, chemical heave, and corrosive soils.	SNBCA 1803.6
	7	Expected total and differential settlement. Provide backup test data and supporting calculations when the allowable soil bearing pressure exceeds 4,000 psf.	SNBCA 1803.6
	8	Pile and pier foundation information in accordance with IBC 1803.5.5 and 1810.	SNBCA 1803.6
	9	Special design and construction provisions for footings or foundations founded on expansive soils.	SNBCA 1803.6 SNCBA 1806.6.1.1 SNCBA 1808.6.2
	10	Soil classification by the USCS. Backup data on test performed shall be included.	SNBCA 1803.6
	11	Classify the expansion level of the soil and specify the minimum embedment depth per Table 1808.6.1.1.	SNBCA 1803.6
	12	Address the possible impacts on adjoining properties and mitigating measures to be undertaken.	SNBCA 1803.6
	13	Suitability of onsite soils for use as fill material.	SNBCA 1803.6
	14	Provide the grading requirements for onsite and import soils including, but not limited to, swell, solubility, and sulfates.	SNBCA 1802.6.14 ACI 318 section 4.3
	15	Geotechnical design considerations for drainage structures.	SNBCA 1803.6
	16	Trenching or other special procedures for determining fault and fissure locations and procedures for mitigating geological hazards. Fault Investigations per SNBCA Appendix P.	SNBCA 1803.6
	17	Erosion control requirements, as applicable (SNBCA Appendix J110).	SNBCA 1803.6
	18	Anticipated structural loads and type of proposed structure.	SNBCA 1803.6
	19	Site Class per 1613.3.2.	SNBCA 1803.6
	20	All lateral earth pressures and seismic forces shall be reported in psf/ft and distributions expressed in graphical form. All resulting forces must have a recommendation on wall placement location.	SNBCA 1803.6
	21	For projects in SDC D or greater determine the lateral pressure on basement and retaining walls due to earthquake motions.	SNBCA 1610.1.1
	22	Ensure the soils report addresses the placement of fill on slopes steeper than 5:1, as needed.	SNBCA Appendix J107, J109
	23	When a post-tensioned slab-on-ground is recommended the geotechnical report must specify the all soil parameters as required by Section 1805.8.2.	SNBCA 1803.6 PTI

## Grading Plan Review Checklist

√	#	Geotechnical Requirements - Soils Report:	Building Review Code Reference
	24	Compacted fill properties and testing in accordance with Section 1803.5.8 SNBCA. Provide provisions to mitigate the effects of collapsible soils, soluble soils, uncontrolled fill, chemical heave, and corrosive soils.	SNBCA 1803.6
	25	Controlled low-strength material properties and testing in accordance with Section 1803.5.9.	SNBCA 1803.6
	26	Anticipated approximate cut and fill depths.	SNBCA 1803.6
	27	Caliche and cemented soils considerations, if encountered. Recommendations for the removal of caliche and cemented soils and/or preparation and grading for foundations on caliche and cemented soils.	SNBCA 1803.6
	28	Specifications for the preparation of the site prior to fill placement.	IBC1803.5.8
	29	Specifications for materials to be used as compacted fill.	IBC1803.5.8
	30	Test method to be used to determine the maximum dry density and optimum moisture content of the fill.	IBC1803.5.8
	31	Maximum allowable thickness of each lift.	IBC1803.5.8
	32	Field test method for determining the in place dry density of the fill.	IBC1803.5.8
	33	Minimum acceptable in place dry density.	IBC1803.5.8
	34	Number and frequency of field tests required to determine compliance.	IBC1803.5.8
	35	Flooding or jetting shall not be used to compact fill material that will support footings or foundation systems.	SNBCA 1803.5.8
	36	Placement procedure for oversized fill material. No rock with a maximum dimension greater than 12" shall be placed in fills within 5 feet, measured vertically from the bottom of the foundation or lowest finished floor elevation.	SNBCA 1803.5.8
	37	Specify the level of special inspection required per Table 1705.6.	SNBCA 1803.6
	38	Liquefaction hazard evaluation, when required, per SNBCA Appendix O.	SNBCA 1803.6
	39	A statement that the grading and foundation plans have been reviewed and are consistent with the stated geotechnical design criteria.	SNBCA 1803.6

## Grading Plan Review Checklist

√	#	Zoning Requirements:	Zoning Review Code Reference (Title 30)
	1	<p>Final Action for Land Use must be approved, plan must show:</p> <ul style="list-style-type: none"> <li>▪ Uses of the parcel of land</li> <li>• Hold harmless/VS not recorded</li> <li>• Conditions of approval from land use shown</li> <li>• Conformance to plans approved by commission action</li> <li>• Legal Description (plat book, parcel map, etc.)</li> <li>• Lot area, width, depth</li> <li>• Habitat &amp; species conservation requirements (applicability)</li> </ul>	30.16
	2	Zoning Overlay Districts requirements	30.48
	3	<p>Site Development Standards requirements</p> <ul style="list-style-type: none"> <li>▪ Designated Natural areas</li> <li>▪ Backing onto collector streets</li> <li>▪ Separations</li> <li>▪ Site Zones</li> </ul>	30.56
	4	<p>Setbacks requirements</p> <ul style="list-style-type: none"> <li>▪ Front, side, rear, corner – street</li> <li>▪ Easements,</li> <li>▪ Drainage/freeway/railroad</li> <li>▪ Special streets</li> <li>▪ Architectural intrusions/enclosures</li> </ul>	30.56.040
	5	<p>Planned Unit Development requirements</p> <ul style="list-style-type: none"> <li>▪ Separation if required</li> <li>▪ Periphery setbacks</li> <li>▪ Sidewalk along one side of street</li> <li>▪ Street Width</li> <li>▪ Paving</li> <li>▪ Overhang property lines (eaves, etc.)</li> <li>▪ Landscaping requirements (location/depth)</li> <li>▪ Visitor Parking</li> <li>▪ Open space improvement</li> <li>▪ Conformance to file plans</li> <li>▪ Compliance to conditions of plan approval</li> </ul>	30.24
	6	<p>Landscape/Screening requirements</p> <ul style="list-style-type: none"> <li>▪ Landscape area/width in relation to property lines, pavement, streets, buildings, traffic control signs and devices, and sight visibility zones</li> <li>▪ Planter size/locations/easements</li> <li>▪ Parking lot landscape</li> <li>▪ 2' swale along street</li> <li>▪ Trash enclosures</li> </ul>	30.64
	7	<p>Parking and Loading Regulations requirements</p> <ul style="list-style-type: none"> <li>▪ Size and number of parking spaces (Sizes-angles-aisles)</li> <li>▪ HC-aisles-angles</li> <li>▪ Truck loading</li> <li>▪ RV spaces</li> </ul>	30.60

## Grading Plan Review Checklist

√	#	Zoning Requirements:	Zoning Review Code Reference (Title 30)
	8	<p>Fences and Walls</p> <ul style="list-style-type: none"> <li>▪ Retaining wall heights</li> <li>▪ Less intense use</li> <li>▪ Decorative rear</li> <li>▪ Decorative wall/fence in conjunction with landscaping</li> <li>▪ Landscape for walls</li> <li>▪ Redundant Walls</li> <li>▪ Flood control/drainage channel</li> <li>▪ Required Walls &amp; locations w/detail sheets &amp; cross sections</li> </ul>	<p>30.64.020 30.64.040</p>

√	#	Stormwater Compliance Requirements The five standard notes below must be included on the site/grading plans for projects that exceed one or more acres	Building Review Code Reference
	1	<p>Standard Note No. 1: The Owner, Site Developer, Contractor, and/or their authorized agents shall each day remove all sediment, mud, construction debris, or other potential pollutants that may have been discharged to, or accumulated in, the public rights of way of the _____ [insert applicable jurisdiction] as a result of construction activities associated with this site development or construction project. Such materials shall be prevented from entering the storm sewer system.</p>	BMP Section 3.5.1
	2	<p>Standard Note No. 2: Additional construction site discharge best management practices may be required of the owner and his or her agents due to unforeseen erosion problems or if the submitted plan does not meet the performance standards specified in the [insert jurisdiction's ordinance reference] and the Las Vegas Valley Construction Site BMP Guidance Manual.</p>	BMP Section 3.5.1
	3	<p>Standard Note No. 3: Temporary or permanent stabilization practices will be installed on disturbed areas as soon as practicable and no later than 14 days after the construction activity in that portion of the site has temporarily or permanently ceased. Some exceptions may apply; refer to the Nevada Stormwater General Permit for Construction Activity NVR100000, Section III.A.5.</p>	BMP Section 3.5.1
	4	<p>Standard Note No. 4: At a minimum, the Contractor or his agent shall inspect all disturbed areas, areas used for storage of materials and equipment that are exposed to precipitation, vehicle entrance and exit locations, and all BMPs weekly, and within 24 hours after any rain event of 0.5 inches or more. The Contractor or his agent shall update or modify the Stormwater Pollution Prevention Plan as necessary. Some exceptions to weekly inspections may apply, such as suspension of land disturbance activities. Refer to the Nevada Stormwater General Permit for Construction Activity NVR100000, Section III.A.12.</p>	BMP Section 3.5.1

√	#	Stormwater Compliance Requirements The five standard notes below must be included on the site/grading plans for projects that exceed one or more acres	Building Review Code Reference
	5	Standard Note No. 5: Accumulated sediment in BMPs shall be removed within seven days after a Stormwater runoff event or prior to the next anticipated storm event, whichever is earlier. Sediment must be removed when BMP design capacity has been reduced by 50 percent or more.	BMP Section 3.5.1
	6	Las Vegas Valley Stormwater Quality management program – Fill out and submit a copy of the Construction Permit Submittal Checklist.	BMP Section 3.5.1
	7	Las Vegas Valley Stormwater Quality management program – Fill out and submit a copy of the Performance Standards Compliance Checklist.	BMP Section 3.5.1
	8	Based on the checklist, if disturbed area is more than 1 acre unless adjacent to a wash. Section 3.5.1	BMP Section 3.5.1
	9	Submit a copy of NOI & a copy of the receipt for payment (or cancelled check sent to NDEP), or submit a copy of the letter of authorization form NDEP (A copy of the receipt for payment of the annual fee that is due at the time of filing is also acceptable).	BMP Section 3.5.1

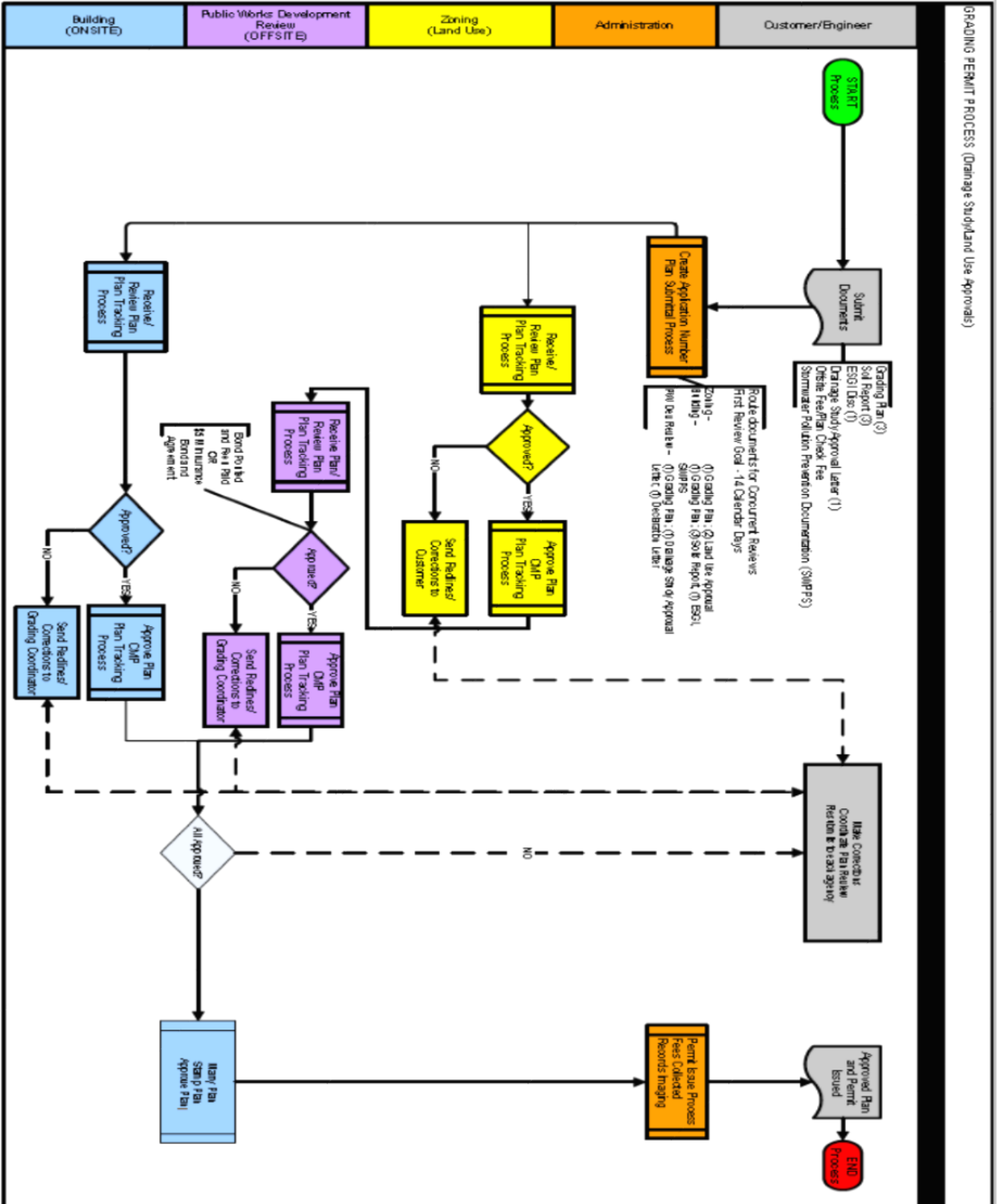

## Department Of Building & Fire Prevention Locations & Services

<b>MAIN OFFICE</b> 4701 W. Russell Road Las Vegas, NV 89118 (702)455-3000	On-Site Plan Submittals All "Walk-Through" Plan Review / Permitting Functions Residential Tract Submittal / Permitting All Sub-Trade (Electrical, Plumbing & Mechanical) Permitting Building Inspection Scheduling Functions Fire Prevention Inspection Services Records	Temporary Certificate of Occupancy Submittals Building Inspections Building Inspector Inquiries Amusement / Transportation Systems Operation Certificates Approved Fabricators Quality Assurance Agency Listing
<b>LAUGHLIN OFFICE</b> Regional Government Center 101 Civic Way Laughlin, NV 89029 (702)298-2436	Building Inspection Services Fire Prevention Inspection Services	
<b>OVERTON OFFICE</b> 320 North Moapa Valley Blvd. Overton, NV 89040 (702)397-8089	Building Inspection Services Fire Prevention Inspection Services	

### Automated Phone System (702) 455-3000

- Option 1:** For all Inspection services or to report a building code violation.
- Option 2:** For information regarding on-site permits or new plan submittals.
- Option 3:** For the Building Plans Examination division or QAA information.
- Option 4:** For the Zoning Plans Examination division.
- Option 5:** For information or copies regarding land development, construction documents, plans or permits.
- Option 6:** To speak with Management staff.
- Option #:** For hours of operation, Office location and website information.

### Other Clark County Departments/Divisions/Districts

Air Quality & Environmental Management	500 S. Grand Central Parkway, Las Vegas NV	(702) 455-5942
Public Works, Development Review	500 S. Grand Central Parkway, Las Vegas NV	(702) 455-4600
Comprehensive Planning	500 S. Grand Central Parkway, Las Vegas NV	(702) 455-4314
Fire Department	575 E. Flamingo Road, Las Vegas NV	(702) 455-7316
Las Vegas Valley Water District	1001 S. Valley View Boulevard, Las Vegas NV	(702) 870-2011
Southern Nevada Health District	625 Shadow Lane, Las Vegas NV	(702) 759-1000
Water Reclamation District	5857 E. Flamingo Road, Las Vegas NV	(702) 668-8888

### State of Nevada

Division of Water Resources	400 Shadow Lane, Suite 201, Las Vegas NV	(702) 486-2770
Nevada State Contractors Board	2310 Corporate Circle, Suite 200, Henderson NV	(702) 486-1100

### Utilities

Nevada Power	6226 W. Sahara Avenue, Las Vegas NV	(702) 402-5555
Southwest Gas	5241 Spring Mountain Road, Las Vegas NV	(877) 860-6020

[www.ClarkCountyNV.gov/building](http://www.ClarkCountyNV.gov/building)